











# Inclined Belt Conveyors - Sanitary - Easy Clean

 304 Stainless Steel	 Highly efficient
 Modular System	 Drum Motor
 IP- 69 K Protection	 Mains Power
 Hygienic Design	 Video Available
 Drawing Available	 Touch Controls



Easy Clean Inclined Belt Conveyor

[Online Enquiry](#)

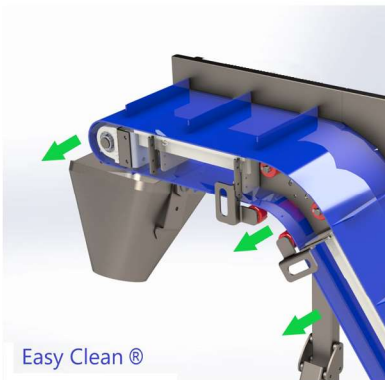

Easy Clean®

Easy access for belt removal



Compact Drive System available



IP-69k Drum Motor

The **SERMAX-OSG**® Inclined Belt Conveyors **IBC** range has been designed for the elevation and feeding of sticky and fragile products up to other devices such as Pneumatic or Servo feeding conveyors, between others. The automation parameters can be programmed in the control touch panel product recipe, in order to ensure a suitable feeding and spreading of the products, a key factor to obtain accurate weights, during the weighing cycle. Key features include:

- |                   |                             |                               |
|-------------------|-----------------------------|-------------------------------|
| + Hygienic Design | + Reduced water consumption | + IP-69k Drum Motor           |
| + FDA components  | + Positive Drive belt       | + Customization possibilities |
| + Easy to clean   | + Mechanical Stability      | + Cantilever Design           |

